

GENERAL ARRANGEMENT SCALE 1:200

M.S. CRYSTAL ISLAND

HISTORY

DRAWN BY THIS WORKS.
June 29, 2011

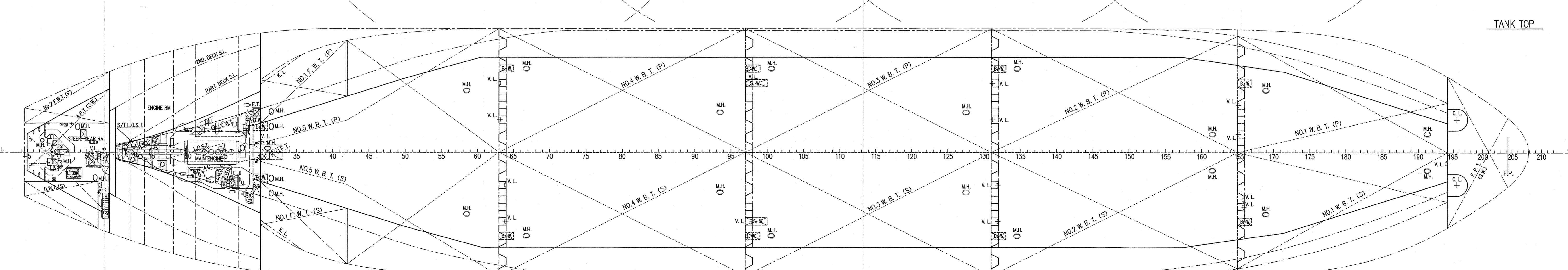
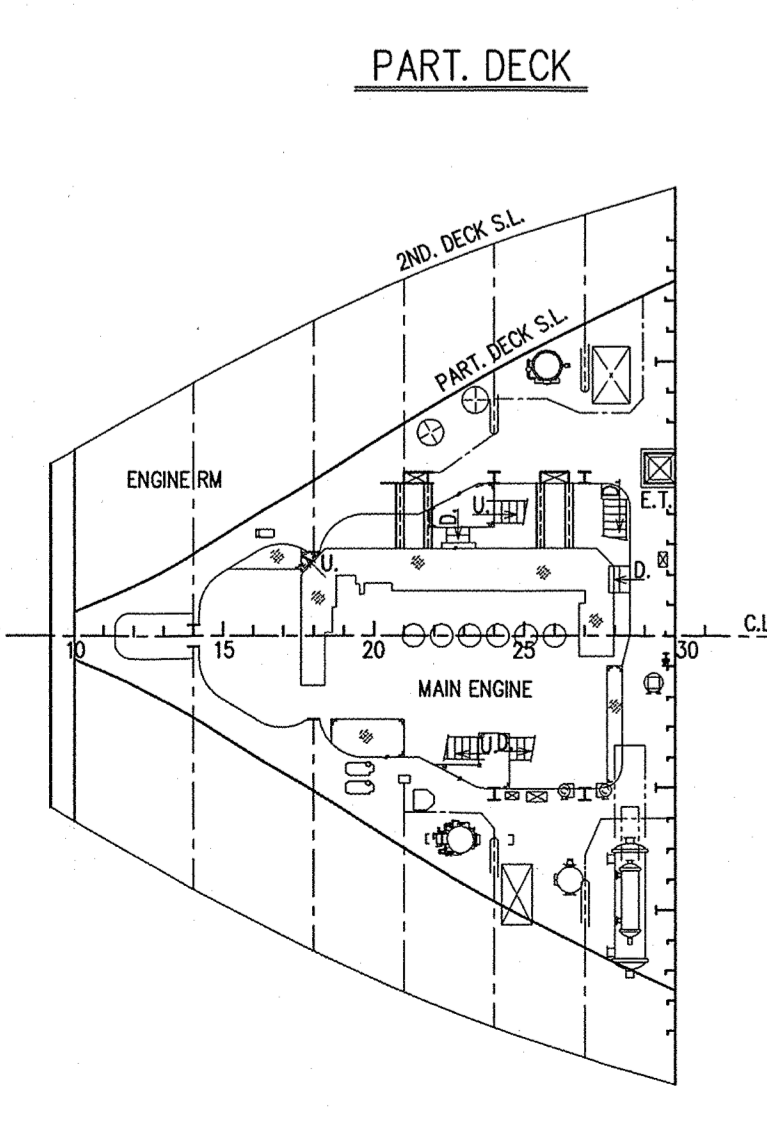
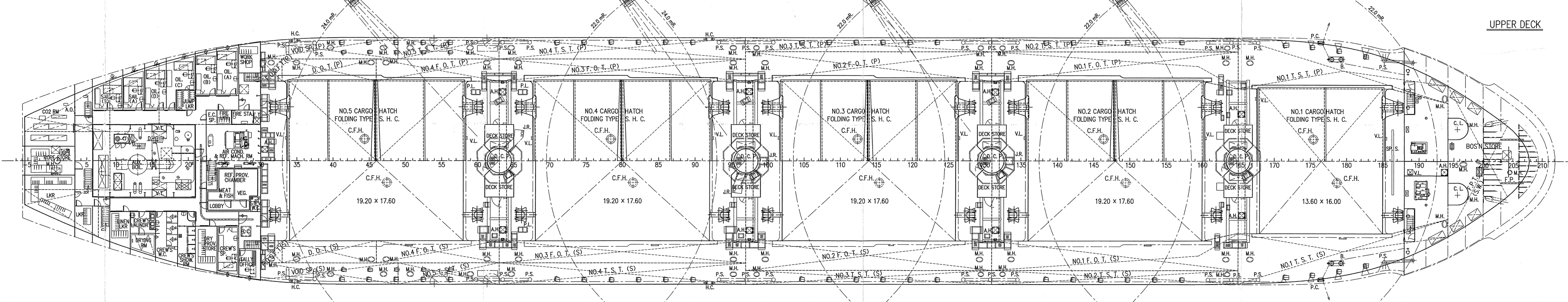
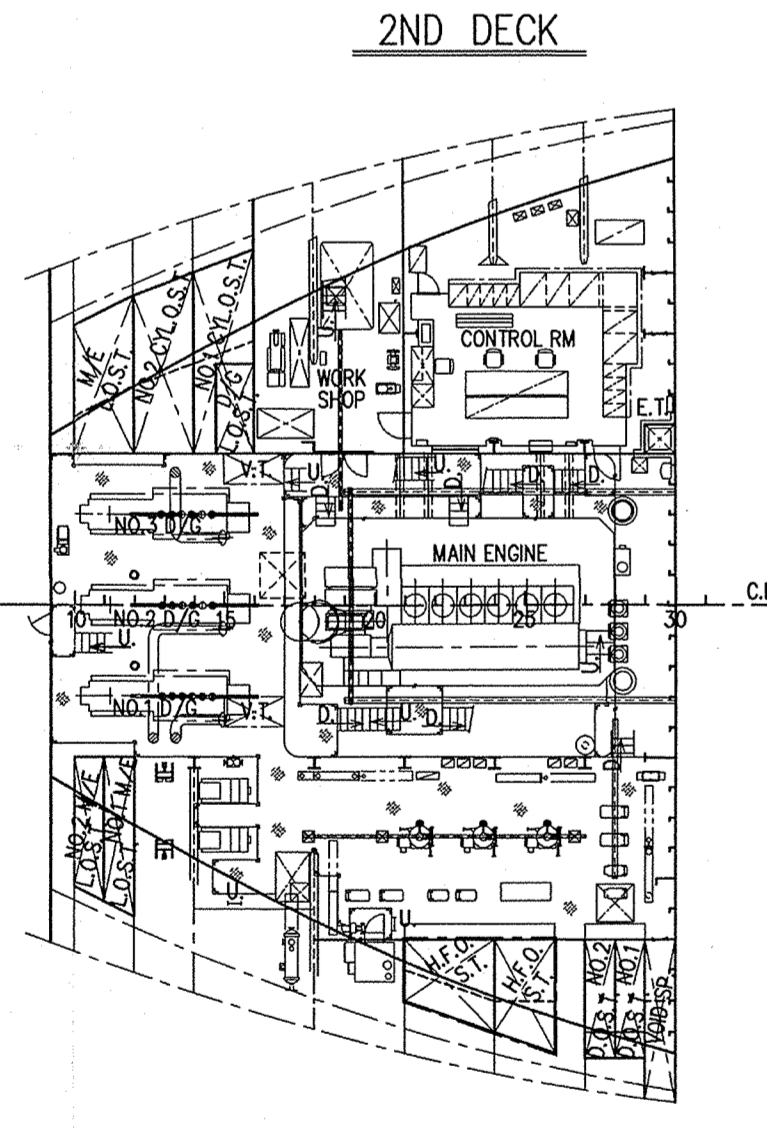
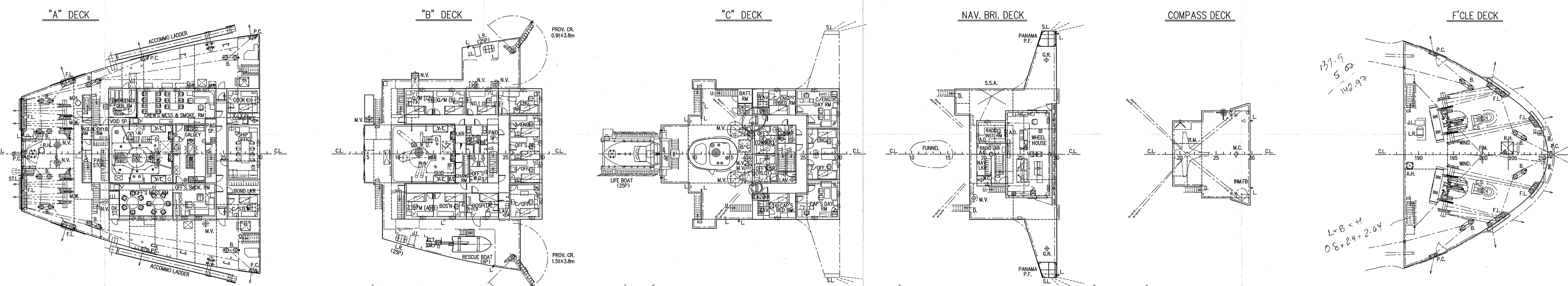
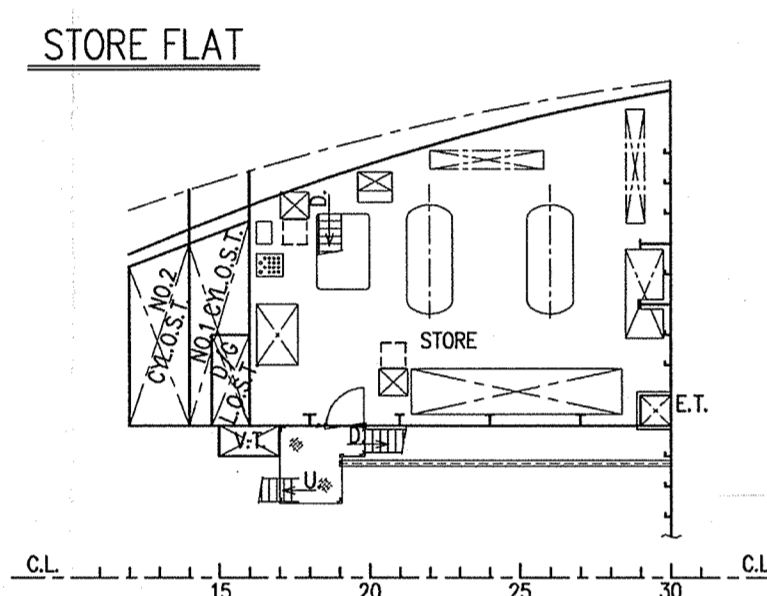
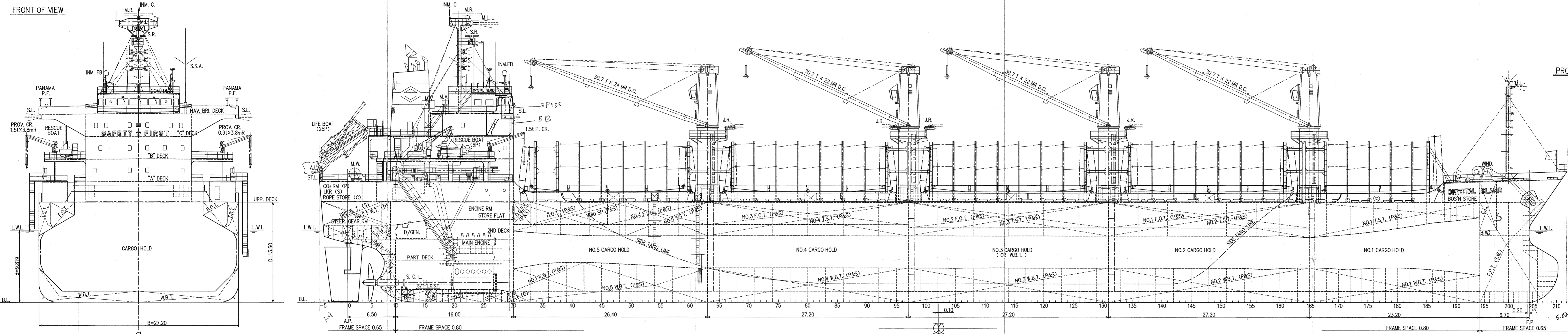

PRINCIPAL PARTICULARS	
LENGTH (O.A.)	169.37 m
LENGTH (B.P.)	160.40 m
BREADTH (M.D.)	27.20 m
DEPTH (M.D.)	13.60 m
DRAUGHT (EXL.)	9.819 m
DEADWEIGHT	28,228 MT
GROSS TONNAGE (I.C.T.M.)	17,027
NET TONNAGE (I.C.T.M.)	10,108
MAIN ENGINE	
MANITEX-MITSUBI-MAN	B & W 6542MC (MARK VI) x 1 set
MARKING OUTPUT	5,650 kw (7,953 ps) x 129 rpm
NORMAL OUTPUT	4,970 kw (6,757 ps) x 122 rpm
	(85% M.C.R.)
HOLD CAPACITY (GRAIN)	37,320.63 m ³
(BALE)	35,742.83 m ³
SPEED	
SERVICE (d = 9.70 m M.D., 85% M.C.R. with 15% S.M.)	14.0 knots
TRIAL MAX.	16.150 knots
CLASS	
NIPPON KAIYU KAI (NK)	
CLASSIFICATION CHARACTERS	
NK NS * (BC-A, BC-XI, GRAB) (ESP) and MMS *	
INSTALLATION CHARACTERS	
CHG, MPP, LSA, RCF, AFS	
DESCRIPTIVE NOTES	
STRENGTHENED FOR HEAVY CARGO LOADING WHERE HOLDS	
NOS. 2 & 4 MAY BE EMPTY	

COMPLEMENT			
DECK PART	ENGINE PART	BUSINESS PART	
CAPTAIN	1 CHIEF ENGINEER	1	
CHIEF OFFICER	1 1ST ENGINEER	1	
2ND OFFICER	1 2ND ENGINEER	1	
3RD OFFICER	1 3RD ENGINEER	1	
BOATSWAN	1 NO.1 OILER	1 CHIEF STEWARD	1
QUARTER MASTER	3 OILER	4 COOK	1
SALOOP	2		
TOTAL NUMBER OF OFFICER CLASS		8 P.	
TOTAL NUMBER OF CREW CLASS		13 P.	
OFFICER'S SPARE (JUNIOR OFFICER CLASS)		1 P.	
CREW'S SPARE (TRAINING CREW CLASS)		1 P.	
OFFICER'S SPARE (OWNER)		1 P.	
OFFICER'S SPARE (PILOT)		1 P.	
GRAND TOTAL		25 P.	

CAUTION
THIS DRAWING OR DOCUMENT IS THE PROPERTY OF MABARI SHIPBUILDING CO., LTD. REPRODUCING, COPYING, UTILIZATION FOR PURPOSES OTHER THAN AGREED, DISCLOSURE TO A THIRD PARTY, ARE STRICTLY SUBJECT TO PRIOR WRITTEN AGREEMENT BY MABARI SHIPBUILDING CO., LTD.

LADY MIRAF

FINISHED PLAN			
CON-FERRED	MABARI DESIGN GROUP	M.S. "CRYSTAL ISLAND"	
	BASIC DESIGN TEAM	IMO 9470325	
APPROVED	T. M. O. I. I.	GENERAL ARRANGEMENT	
CHECKED	S. T. S. I. I.		
CHECKED	S. T. S. I. I.		
DRAWN	S. T. S. I. I.		
SHIP NO.	CLASS	SCALE	DWG. NO.
S-H592	NK	1/200	C-0200